

# Specification

formulate	verify	approve

examine	confirmation	authorize

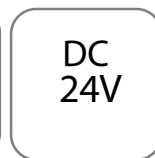
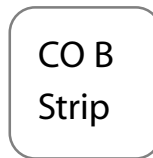
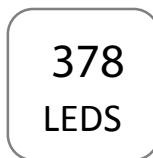

Item No : YS -F08COBC -X378

5000\*8, 1890 pcs COB Non waterproof White color Constant voltage 24VDC

Flexible Strip light

**Picture :**

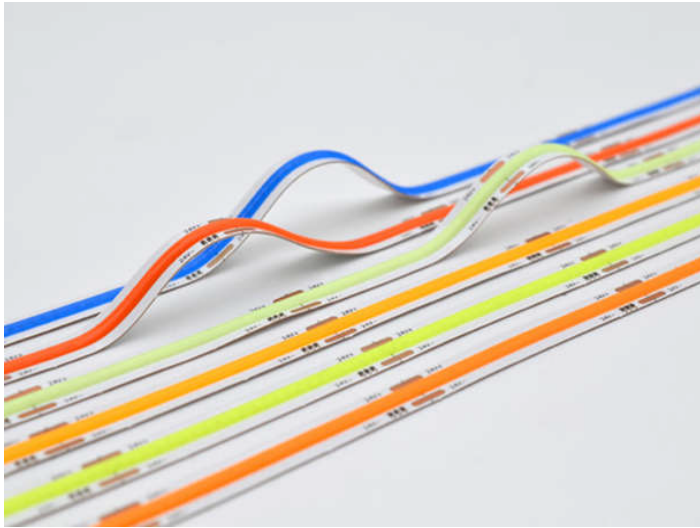

**Features :**

No Spot , No Shadow , Soft light

Beam Angle: can meet 180°

Antistatic rating(MIL -STD -883E) : HBM Level 2 (2000~4000V)

Easy to install and maintain. It can be bent freely, with adhesive at back, and the daily maintenance is convenient; This product don't contain any hazardous substances and RoHS Standard compliant.

This product don't contain any hazardous substances and RoHS Standard compliant.

**Application :**

Decorative lighting, cabinets, display cabinets, home lighting, hotel, shopping mall auxiliary lighting, etc.



**Warranty :**

3years warranty ;

**Parameters :**

Item No.,	LED Color	CCT (K) Wavelength (nm)	CRI Ra	Color tolerance SDCM	Beam Angle (°)	Luminous Flux (lm/m)	Lighting effect (lm/W)	Input Voltage (VDC)	Current (mA/m)	Power (W/m)
YS -F08COBC -X378	Warm white	3000K	90	5	180	900	90	24	417	10
	Neutral white	4000K	90	5		1100	110			
	Pure white	6500K	90	5		1000	100			

	Red	620-630	/	/	180	200	20	24	417	10
	Green	520-530	/	/		600	60			
	Blue	450-460	/	/		120	12			
	Yellow	585-595	/	/		500	50			

Other parameters :

Item No.,	IP Rate	Working temperature ( )	Storage temperature ( )	Standard Size (mm)	Max connection (m)	LED Qty (pcs/m)	Weight (g/m)
YS -F08COBC - X378	IP20	-25~+45	-25~+70	5000*8	5	378	13

Remark :

- (1) Test environment temperature is 25±2 (normal temperature) ;
- (2) The above data is typical, the actual parameters of the product may differ from the typical data; the data is subject to change without notice
- (3) The above "-" indicates that the parameters of this product are not required at the moment ;

Dimension (Unit:mm) :

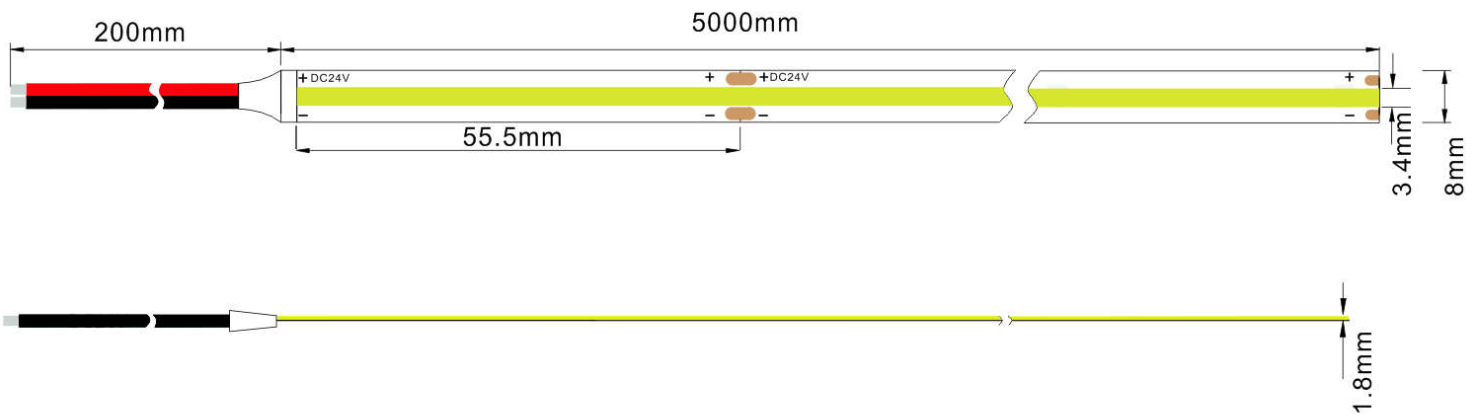

YS -F08COBC -X378

Distribution curve/ illuminance diagram :

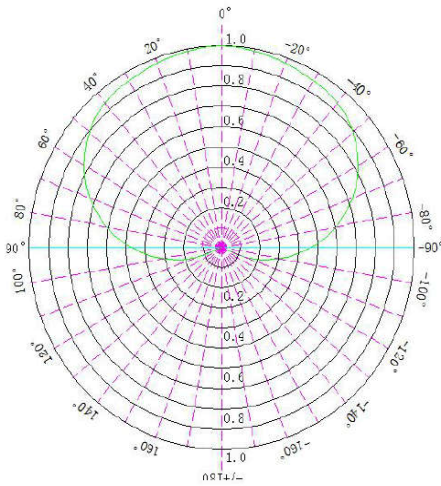

2.281ft 1m	4.196,14.80lx 48.17,189.9lx	9.754ft 297.29cm
6.562ft 2m	1.049,2.574lx 11.29,40.47lx	19.51ft 594.58cm
9.843ft 3m	0.4662,1.589lx 3.019,17.10lx	29.26ft 891.87cm
13.12ft 4m	0.2622,0.9938lx 2.823,9.618lx	29.01ft 1189.17cm
16.4ft 5m	0.1679,0.8719lx 1.807,6.165lx	48.77ft 1486.46cm

Color coordinate distribution range :

### Spectroscopic target Drawing (SDCM ≤ 5)

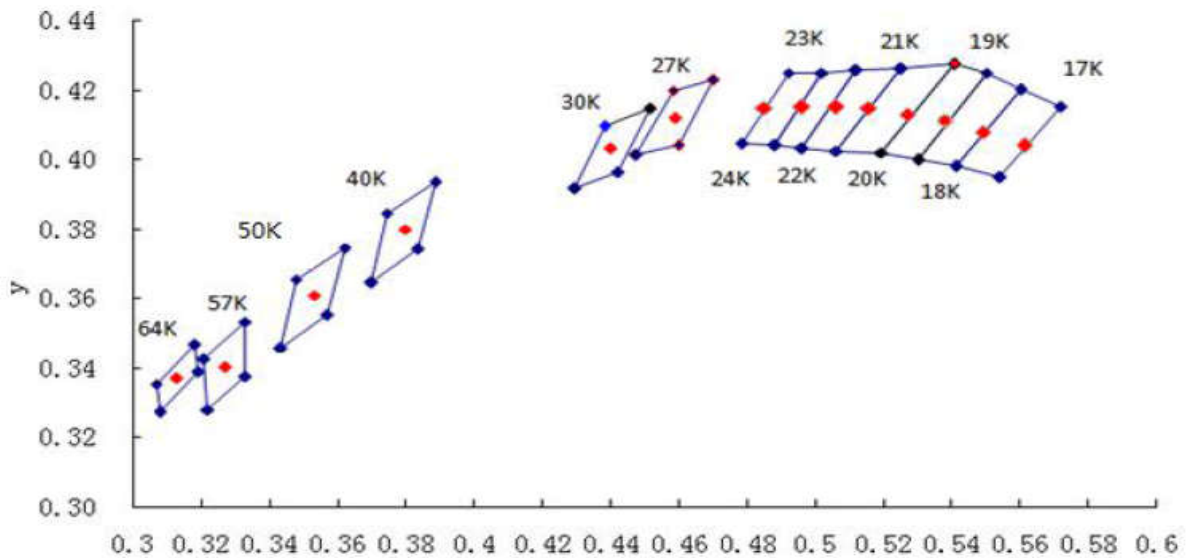

Packaging :

Item No.,	Qty per Rolls(m )	Qty per carton (m)	Total Weight (Kg)	Dimension of outer carton (mm)		
				Length	Width	Height
YS -F08CO BC -X378	5	300	7.5	520	300	220

Remark : The above packing quantity and weight only refer to the packing method as shown in the diagram. When other packing methods are adopted, there will be differences in packing quantity and weight. Please subject to the actual product.

## Packaging drawing :

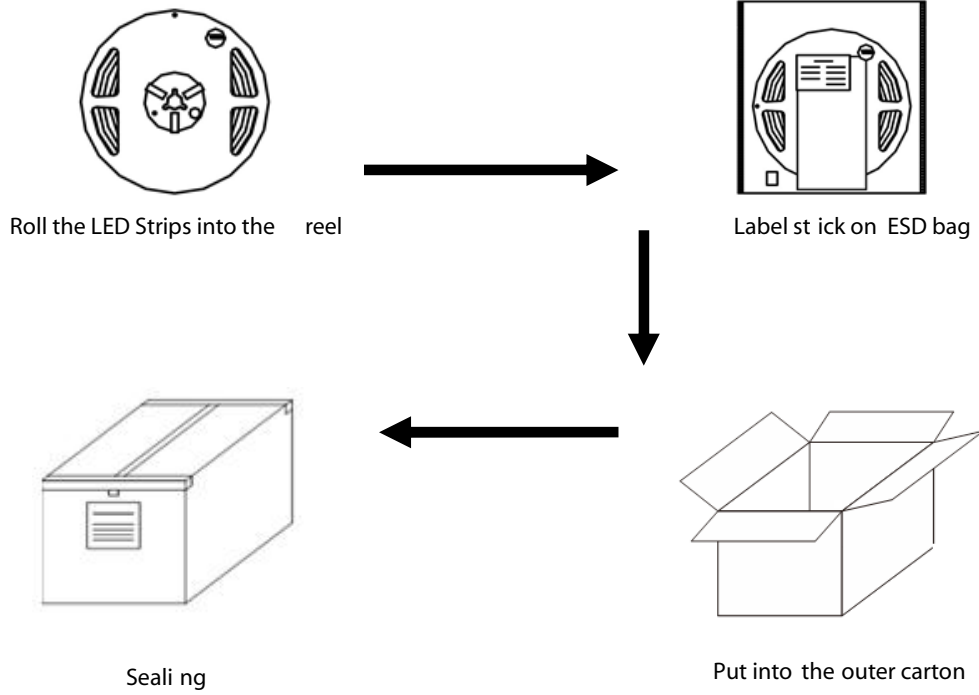

## Installation :

(Remark : The positive and negative wire need to be correctly connected to the positive and negative terminals of the power supply output.)

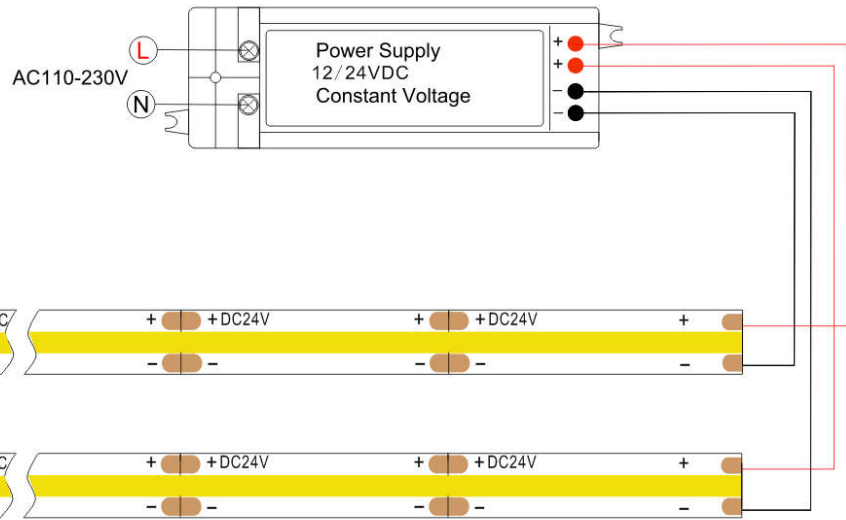

Red wire is positive and black wire is negative

## Installation step instructions and precautions :

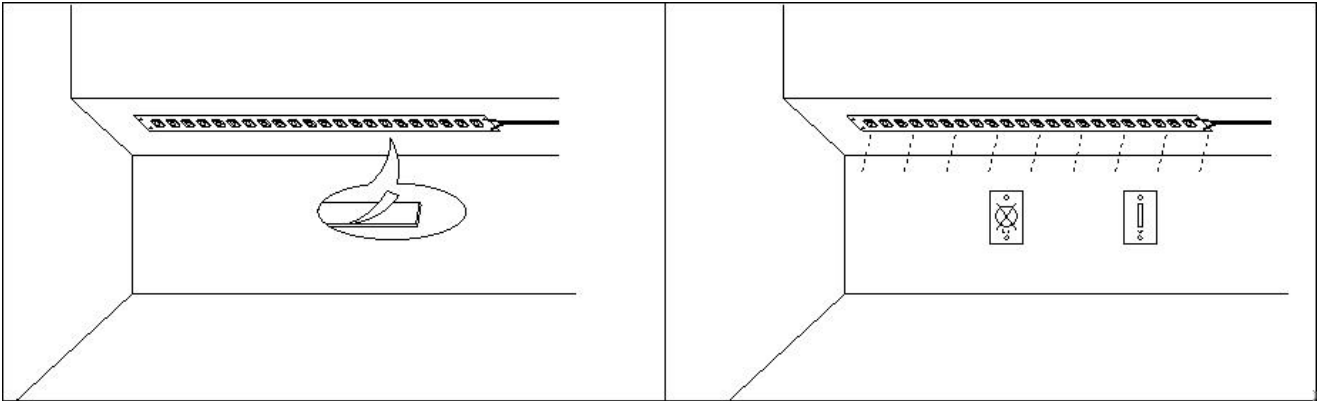

Clean up debris on the mounting surface to ensure surface cleaning

Measure the length of the LED strip to be installed, and cut the extra lamp strip along the scissors marking line.

When attach the led strip, the paper of back side that is peeled off slowly and the stick it meanwhile. It is forbidden to tear off all the release paper at one time, so as to prevent the strip from sticking to each other.

After the led strip is installed, the light strip is connected to the power output. Insulate, short-circuit and anti-corrosion treatment at the terminals and ends.

### Precautions:

1. Pay attention to protect the LED light strip to avoid touching the hard objects in the light -emitting area.
2. Please weld in 24H after unpack ed, to avoid welding effect on the welding point. Please use vacuum seal the products that have not been used after opening.
3. Avoid direct contact of high -temperature objects in the light -emitting area of the lamp, and the instantaneous contact temperature of the surface of the light -emitting area should be less than 210 °C.
4. The temperature of the soldering iron should be less than 400° when soldering, and the soldering time of single pad should be controlled within 3s.
5. It is strictly forbidden to twist the lamp with short distance. The single lamp has a maximum twist angle of 720°; the ben d diameter at any position needs to be greater than 2cm.

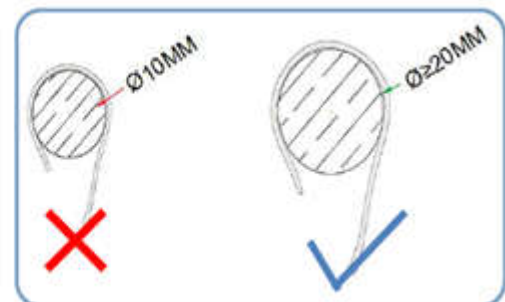
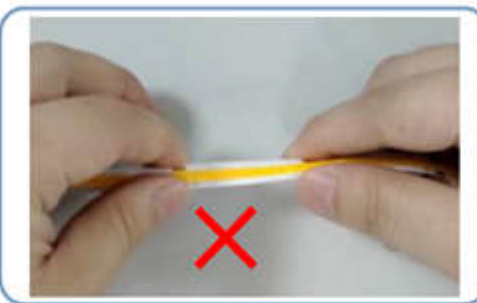
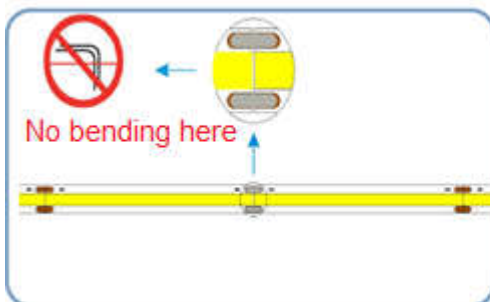

## Common faults of products and troubleshooting methods :

Fault phenomenon	potentia l causes	Solution
All LEDs are off	1、 The power is off.	power transmission
	2、 Automatic protection of the power supply after the output of the switching power supply is open or shorted.	trouble shooting and recovering the power supply
	3、 LED Strips with power supply terminal polarity reverse	Check the wire connection to ensure correct connection of positive and negative wire
Some of the LEDs are off	1、 Part of the switching power supply is not powered	Check the power supply system and troubleshoot
	2、 Part of the electricity supply line error	
	3、 Partial led strips with reverse polarity connection	Correct connection
LED brightness is not the same or the brightness is not enough	1、 Power overload	Replace the power supply with a larger power according to the load
	2、 Switching power supply line or circuit loss is too large	Ensure that the operating voltage of the led strips is within $\pm 5\%$ of the rated voltage 1. Cut the length of the wire between the strip and the power cord or use wires with larger diameter; 2. Ensure that the number of each led strip is less than or equal to the maximum allowable cascade ;And make each strip with a similar connection.
	3、 Over connection of LED Strips	Adjust the number of strips for each power supply and to meet the maximum connection requirements for each power supply.
LED flashing	1、 Poor contact at the wiring point	Find out the bad points and troubleshoot.
	2、 Switching power supply failure	Replace the switching power supply

## Statement :

If the external cord of the product is damaged, it should be replaced by the manufacturer or its service agent or a similarly qualified person to avoid danger. For the specific installation and precautions of the product, please refer to the product manual.

The data above in this specification is based on standard products. Actual shipments may be a little difference. Please refer to the actual product.

All product drawings in this specification are schematic diagrams, and actual shipments may be a little difference. Please refer to the actual product..

## SHENZHEN YESUN LED Limited

Address : 3/F, Blog A3, Langxin industrial park, Shiyan Street, Bao'an dist., Shenzhen, Guangdong, China

Tel: 86 -755 -29049310

Email: info@yesun-led.com

Web: www.yesun-led.com